

# Journal of Engineering Research

## SOFT ARCHITECTURE: APPLICATION OF SOFT ROBOTICS IN THE DESIGN RESPONSIVE- INTERACTIVE ARCHITECTURE

---

*Cristian Aroca*

Universidad de Chile, Santiago, Chile

*Sebastián Rozas*

Universidad de Chile, GT2P, Santiago, Chile

All content in this magazine is licensed under a Creative Commons Attribution License. Attribution-Non-Commercial-Non-Derivatives 4.0 International (CC BY-NC-ND 4.0).



**Abstract:** The main objective of this research is to develop a method that can integrate responsive and interactive architecture through the application of soft robotics on a façade. To achieve this objective, a review of the main concepts, adaptive architecture (responsive-interactive) and soft robotics was first carried out. Secondly, recent studies and research that speak of the application of soft robotics in architecture are analyzed. With the knowledge acquired in the analyzes and reference studies, together with the help of programming and computational design tools, a scalable physical prototype was developed that manages to integrate both types of adaptive behaviors (responsive-interactive) in a single hybrid robotic system (soft-rigid), demonstrating the potential of soft robotics in architecture, in this case being applied to be sensitive and act on changes in temperature produced by solar radiation.

**Keywords:** Robotics, Generative Design, Adaptive architecture, Sustainable Design, Soft

## INTRODUCTION

This work investigates the intersection of three general areas, adaptive behavior architecture, soft materials and robotics. Specifically, the research area is responsive and interactive architecture through the implementation of Soft robotics.

Currently, the adaptive systems used mostly only respond to an external variable, for example, climate changes (responsive), leaving aside the internal variable (interaction) where the use of space and human behavior is relevant. As in most cases the response of the adaptive system is unidirectional, that is, it only responds to the exterior or interior (not to both), the interaction that is associated with the user goes to the background, so there is no direct relationship between responsiveness and interaction. The implementation of soft

robotics in adaptive behavior architecture arises as an opportunity to investigate how the properties of soft materials can contribute to improve the possibilities of involving the inhabitants of the place in a direct interactive exchange between them and their built environment (Al Faleh. O, 2017).

In the article *Soft Systems: Rethinking Indeterminacy in Architecture as Opportunity Driven Research*, Dickey R (2017), through a compilation of recent research, uses the concept of indeterminability to refer to soft materials due to their deformative, non-linear, and unpredictable properties. He also proposes to reconsider that the indeterminacy of the material, commonly seen as an element of chance due to its changing shape and alterable nature, is seen more than as an obstacle, as an opportunity to design and study regarding indeterminacy in relation to human behavior (Dickey R, 2017) as a possibility of interaction.

So, this article will seek the intersection of architecture and soft robots, with the aim of contributing to the development of responsive and interactive architecture—which is scarce today—through the study of soft robotic systems and their material properties as a means to integrate both behaviors (responsive and interactive) into a single system.

## BACKGROUND

### ADAPTIVE ARCHITECTURE

Adaptive architecture, in the words of Omar Al Faleh (2017), arises from the intersection between architecture, design and technology, that is, it is a field of architectural design that benefits from technology to create autonomous systems capable of adapting to the environment it is facing (responsive or interactive). In practical terms, when adaptive architecture is environmentally responsive it can help control and reduce a building's energy

consumption by learning and responding to weather patterns through morphological changes in the building, promoting more sustainable architecture. Energy performance is part of the functional purpose of adaptive architecture, but so are protection from environmental agents (rain, wind, pollution, etc.), comfort (thermal, lighting, air quality, etc.), among other things.

Although it is true that today the main focus of adaptive architecture has more to do with an environmental and energy efficiency perspective, adaptive systems until the end of the 20th century and the beginning of the 21st had more to do with aesthetic, temporary and interactive elements that sought to demonstrate the potential of these systems, than with something functional and permanent in a building.

In general, adaptive systems can be classified according to the variable to which they respond (whether they respond to the external environment or the internal environment), according to the type of system (facade, lighting, acoustics, etc.) and its activation method (if it is active or passive depending on the use or non-use of electrical energy).

## SOFT ROBOTIC

Within robotics there are two categories in which robots can be classified according to the materiality with which they are built, those made of hard materials and those made of soft or soft materials. Hard or rigid robotics represents the common robots that we have in our imagination when we hear the word, the one that is made mostly of metal, with joints and complex mechanisms also made of rigid materials. Rigid robots commonly work through electric actuators (motors and solenoids) or with pressurized fluids (pneumatically or hydraulically). Soft robotics, unlike rigid ones, and as the name

implies, are made of soft and flexible materials that have the ability to easily deform, making them versatile, adaptable, efficient, and safe for human interaction.

According to Medina and Vélez (2014) we can currently identify two approaches with which the idea of “smoothness” is worked on in the robotics field. The first approach consists in the use of conventional (rigid) robots that have been modified with soft parts in order to have a safer behavior, since they share a work space with people. Such are the cases of food-handling robots with soft grippers present in the food industry. The second approach, more radical than the previous one, deals with intrinsically soft robots, that is, both their bodies and actuators are made of soft materials whose modulus of elasticity is in the order of 10<sup>2</sup> -10<sup>6</sup> Pa, that is, between 3 and 10 times less rigid than conventional robots (Majidi, 2014).

This approach is made possible by advances in recent decades in technologies such as 3D and 4D printing, shape memory smart materials, metamaterials, and pneumatic actuators. Currently, in practice, the first approach is the most used, since most of the development of soft robotics is focused on actuators and soft components that complement complex rigid machines, generating hybrid robotics. The use of soft components in rigid robots is a good idea considering some limitations that these have. According to Whitesides (2018) we can recognize elements that rigid robots lack and that can be complemented or otherwise fully covered with soft robotics. Among them are the low collaboration and compatibility with humans, the low simplicity which leads to high construction costs, and the low thermodynamic efficiency which consequently can lead to high energy use.

## METHODOLOGY

This study is comprised of two methodological procedures, the first of background collection, study of referents and review of recent research. And the second experimental exploratory, where we worked under two types of explorations, an interactive behavior, where various types of interactions (gestures) were worked on and how to take them from the digital world to the physical and, a responsive behavior, where we sought to apply soft robotics through the use of an SMA (nitinol), so that the facade is also responsive to the sun.

## EXPERIMENTATION

Sé chose a façade as a case study because the façade is the place where responses to both the exterior and interior are found. This makes it a border between both media, providing great potential to integrate adaptive behavior from the responsive and interactive point of view, due to this, a geometric framework (grid) composed of adaptive modules that allow such responses was designed.

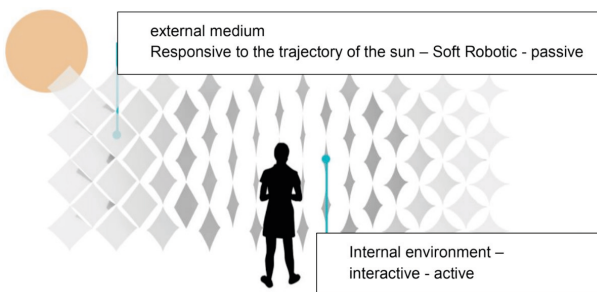

**Figure 1.** Form of behavior of the responsive and interactive system. Own elaboration.

Given the initial problem that adaptive systems only respond to one variable, whether to an external or internal environment, in terms of types of movements performed, it translates all the time to one, open or close, up or down, among others. Therefore, for the design of this façade it was important to integrate two different types of movements

(Fig. 2), one intended to respond to the trajectory of the sun and the temperature changes associated with it, and another for human interactions.

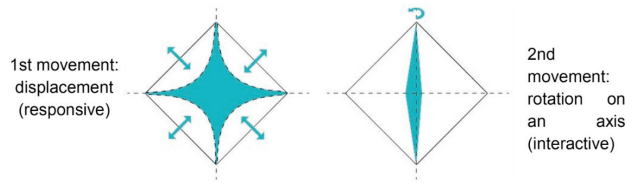

**Figure 2.** Types of movements of the adaptive facade. own elaboration.

Another fundamental aspect of the design is that the action of responding to the external environment was sought to be passive, particularly for two reasons, to reduce the complexity of the system and to save energy. These conditions make the use of soft robotics and soft elements ideal in the responsive part of the project.

The interactions are linked to other types of factors and elements that require a constant supply of electrical energy, such as the sensors that will capture the movements of people and the controllers that will process and give orders to the façade on how it must act based on a schedule. This way there will be different types of integrations or hybridizations in the same façade, passive/active, Robotic/Soft robotic and Responsive/interactive.

At this stage of the work, the use of computational design and simulation tools was essential. For the construction of the digital model, algorithmic and parametric modeling techniques were used through the rhinoceros software together with the Grasshopper plug-in. In addition, simulation plug-ins were used, such as ladybug, which extracts real environmental data, and kangaroo 2, which allows simulation of soft elements. This is important because the responsive part of the project is the one that integrates soft robotics and soft materials. The joint work of both plug-ins allows to simulate the behavior of the

façade (soft robotic) before the position of the sun.

### INTERACTIVE BEHAVIOR

The interactions required a workflow through the hybridization of different devices, to ensure that the interactions are reflected in both the digital and physical models (Fig. 3). This way, the device in charge of capturing the interactions was a Kinect, a device originally created for interactive games for the Xbox 360 console. The decision to opt for this device and not for another, such as an ultrasonic sensor, happened because in the first place, the kinect includes 3 sensors, IR laser, RGB camera and depth camera, in addition to incorporating microphones. This enables accurate detection of both space and motion. The interesting thing about the kinect, in addition to its sensors, is that it is compatible with the grasshopper firefly plug-in, which makes it possible to detect human presence through a skeleton represented in rhinoceros. Firefly through grasshopper is essential at this stage of the work, because in addition to being compatible with kinect, it is the one that allows a direct flow between the digital model and the Arduino. Thanks to information on turns (angles) obtained from the digital model, a servomotor can be ordered to make exactly the same movement, all this through the firefly-Arduino connection.



**Figure 3.** Hybridization of different electronic elements. own elaboration.

The interactions were divided into two types, gestural and automatic. Gestural interactions are those that require a voluntary movement to be able to open or close the façade, unlike the automatic ones where the façade opens or closes depending on the

presence of the person, without the need for any specific gesture.

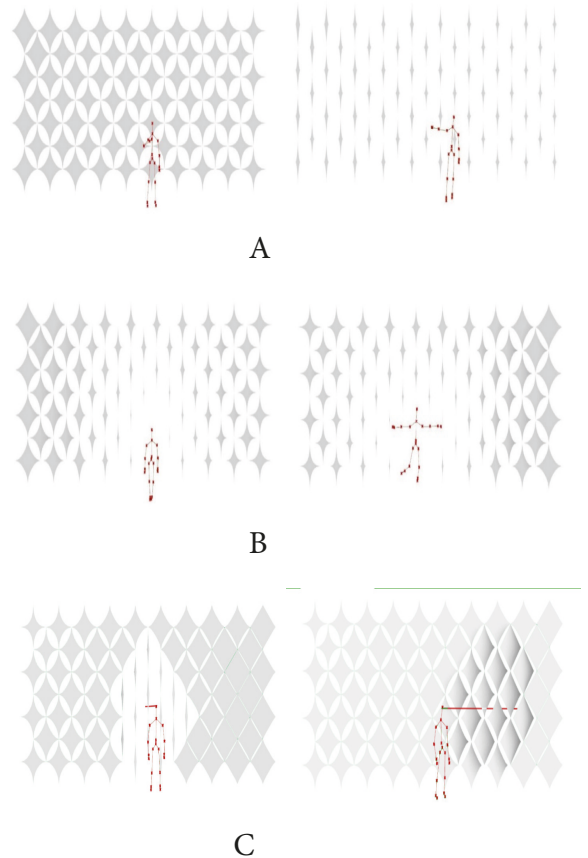

**Figure 4.** (A) gestural interaction, activated with a hand gesture, (B) automatic interaction, the façade is activated where the person is (C) automatic interaction, the façade opens in the area where the person is looking. Own elaboration.

To finish the experimentation of the interactive part, a physical test model (A) was built. In order to verify that the connection with Arduino is successful, and that it is capable of reproducing the movements of a selected module in the digital model (B) (Fig. 5).

### RESPONSIVE BEHAVIOR

The study of the responsive behavior of this research is the one that is designed to integrate the soft robotic to this responsive-interactive facade system.

As an actuator, it was decided to use a metal alloy with shape memory (SMA), in this case, nitinol. Nitinol is an alloy of nickel and titanium in almost equal proportions (45% and 55% respectively) that occurs in two stable phases, one at high temperature, austenite, and the other at low temperature, martensite. When nitinol is in the martensite phase, it is easily deformable, but when a source of heat or electrical energy is applied to it, it enters a transition stage until it reaches the austenite phase, where the material returns to its original shape with superelastic properties. After cooling, the nitinol returns to the undeformed martensite phase.

The responsive experimentation of the work consisted of two parts. The first was to manage to reprogram a nitinol ( $T^{\circ} 40^{\circ}\text{C}$ ) from a linear shape to a spring shape and the second was to perform the force-counterforce exercise of nitinol with a rubber band or elastic.

The idea of the second exercise is that when the nitinol is in the martensite phase (easily deformable phase) it takes a shape stretched by the contraction of an elastic, however, when the transition heat is applied, the nitinol returns to its original shape (spring) (Fig 6). This applied to the façade follows the logic that when the nitinol receives sufficient color from the sun, it will contract, closing the façade. When the nitinol stops receiving the heat or radiation necessary for its transition from the martensite to the austenite stage, it will stretch again due to the tension of the elastic, reopening the façade.

## PROTOTYPE

The final prototype consists of a 30x30 cm module of the façade grid. This consists of three important parts. In the first place, the outer frame that has the role of supporting the other elements. Secondly, the inner framework that is where both movements occur (responsive-

interactive) as well as containing the soft robotic. Lastly, the support bars at both ends of the outer frame. The bars are where the turning mechanism (servomotor) is located, which is in charge of the interactive part of the project (Fig. 7).

The nitinol used for this work has a transition  $T^{\circ}$  of approx.  $40^{\circ}\text{C}$ . When working together with the elastic, in the tests carried out by subjecting the nitinol to heat with a hair dryer, it was able to contract between 4 and 5 cm, managing to almost completely close the façade (Fig. 8). I also know how to test the responsive system in exposure to the heat of the sun. With a temperature of  $28^{\circ}\text{C}$ , nitinol was able to contract 1.5 cm maximum, in the first 5 minutes after exposure, maintaining the length after that. This result is very encouraging, taking into account the high transition temperature of the nitinol used, so that, in a hypothetical case, it was decided to make a façade for a building, a nitinol with a transition  $T^{\circ}$  of 20 to  $35^{\circ}\text{C}$  would be enough for the façade to function correctly.

The soft robotic of the responsive system is completed by a skin, which consists of a mesh made of soft material, in this case an elastic fabric that allows it to deform, adapting to the movements of the nitinol.



**Figure 8.** Closure of the facade through nitinol before and after exposure to heat. Own elaboration.

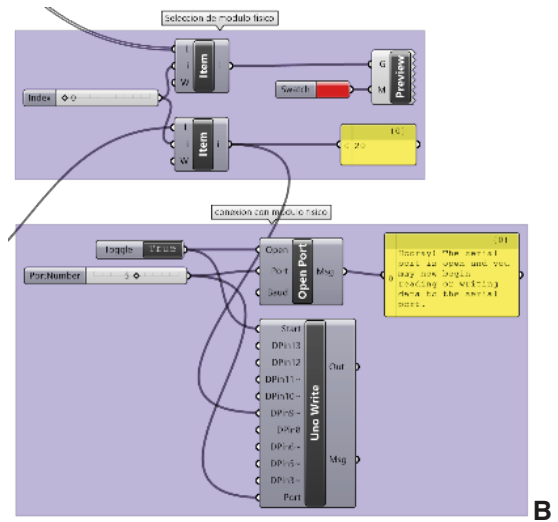
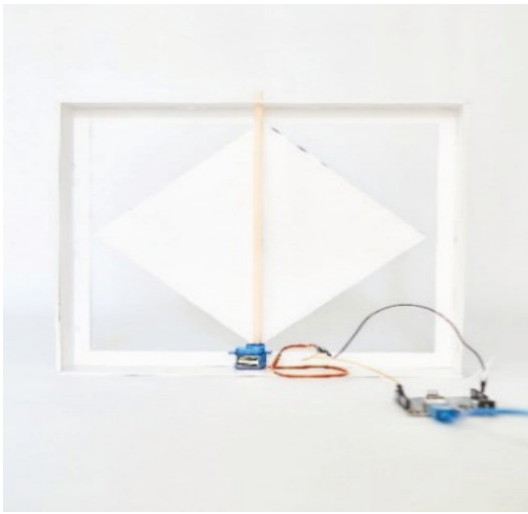

**Figure 5.** A ) Physical test model. (B) Digital module selection script. Own elaboration.

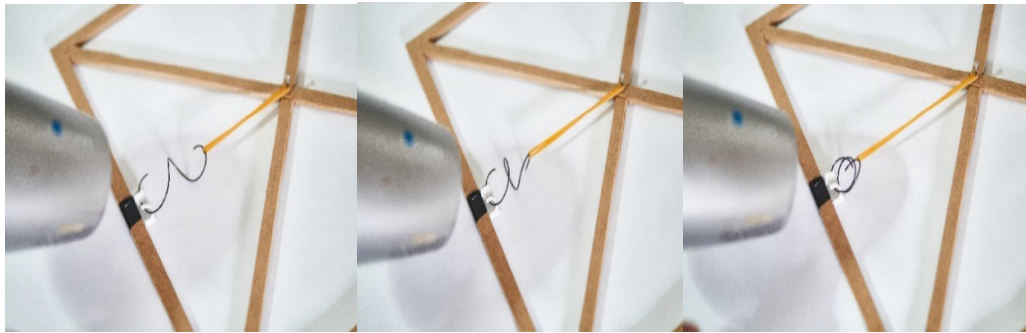

**Figure 6.** Tension and contraction test of nitinol and rubber band, after applying heat with a hair dryer. own elaboration.

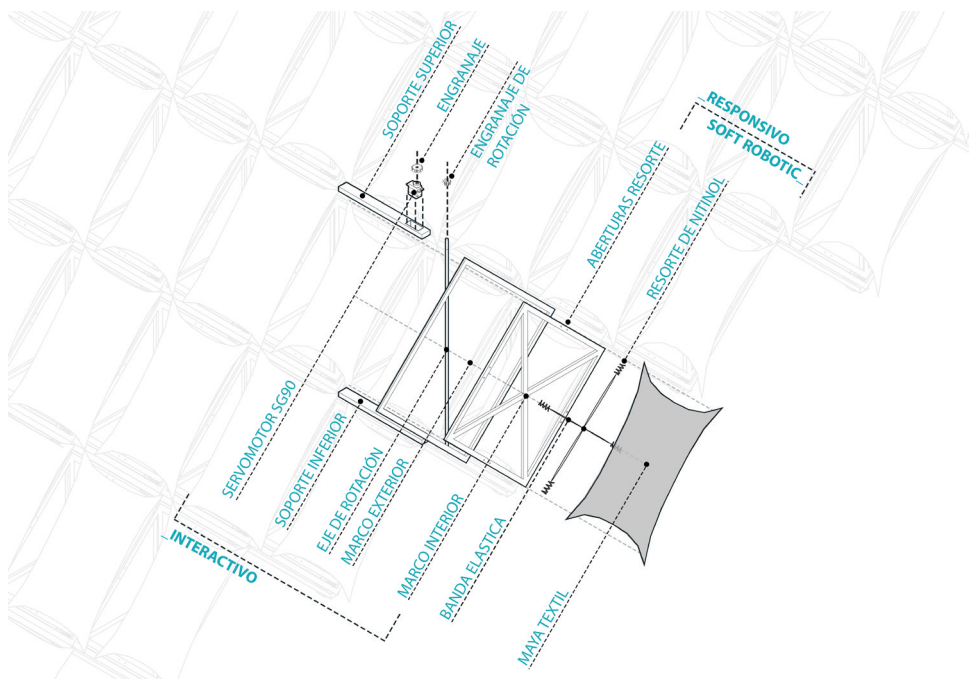

**Figure 7.** Isometric exploded view of the parts of the physical prototype module. Own elaboration.

The prototype (Fig. 9) works in such a way that, when establishing the connection between Arduino, the kinect and grasshopper, it begins to respond to the programmed interactions, being able to choose which interaction you want to be active. At the same time, using the soft robotic, it is possible to modify the opening of the skin with a heat source from approximately 35 to 40°C.



**Figure 9.** Prototype of the responsive-interactive system (Adaptive Module, Kinect, Arduino). Own elaboration.

## RESULTS

1. The prototype has the expected behavior, since it manages to have a passive response when it is exposed to heat and an active one with the interactions, all in the same integrated system.
2. The expressions or gestures of which the interactive part of the work is composed have great potential for customization. There is the possibility that, just as certain own interactions were programmed (for being the author), the system can also be customizable from the point of view of the person who uses it, understanding that each person may have a different way of making gestures for certain actions. This way the system could act according to the user and not only in a pre-established way.
3. The programming of the nitinol used

was relatively simple. It was this way because the nitinol of the prototype came previously trained and with a specific transition  $T^{\circ}$  (40 °C). We also experimented with an untrained nitinol that did not have transition  $T^{\circ}$ , having to assign it yourself, which is difficult if you do not have specific elements to measure heating cycles and temperature, in addition to ovens that reach high temperatures.

4. It was possible to make this integrated system through the hybridization of different previously designed elements that are not necessarily made for what they were used in this research. The way to integrate them was through the use of grasshopper and its pluing, which in addition to soft robotics, allowed the creation of a hybrid robotic system capable of adopting both adaptive behaviors (responsive-interactive).

## DISCUSSION

An architecture that is capable of adapting to environmental changes but that at the same time takes human presence into account, supposes an architecture that is not static and that evolves in both directions, which can have endless benefits. On the one hand, if we look at it from a responsive point of view, being able to adapt to changes in the environment makes it possible to protect external elements, being able to increase the life expectancy of a building and also reduce energy consumption, among other things. From the interactive point of view, it is interesting to reflect on an expressive architecture, which is capable of recognizing what activities are taking place within a space, and adapts its morphological conditions to improve the realization or even enable said activities.

When starting this research, the theory indicated that soft robotics could have



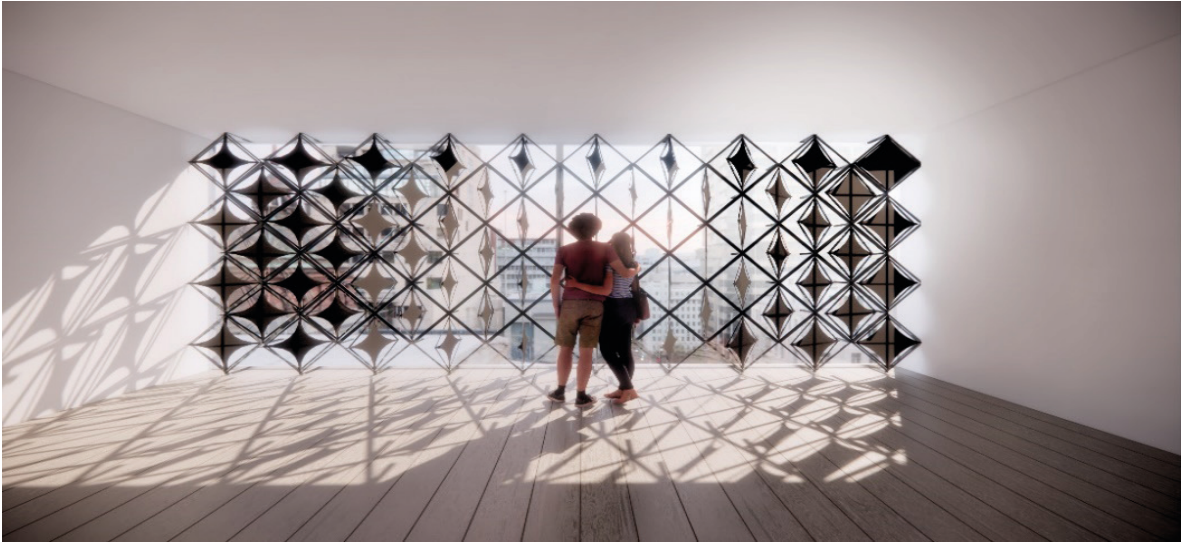

Figure 10. Objective image of the facade. own elaboration.

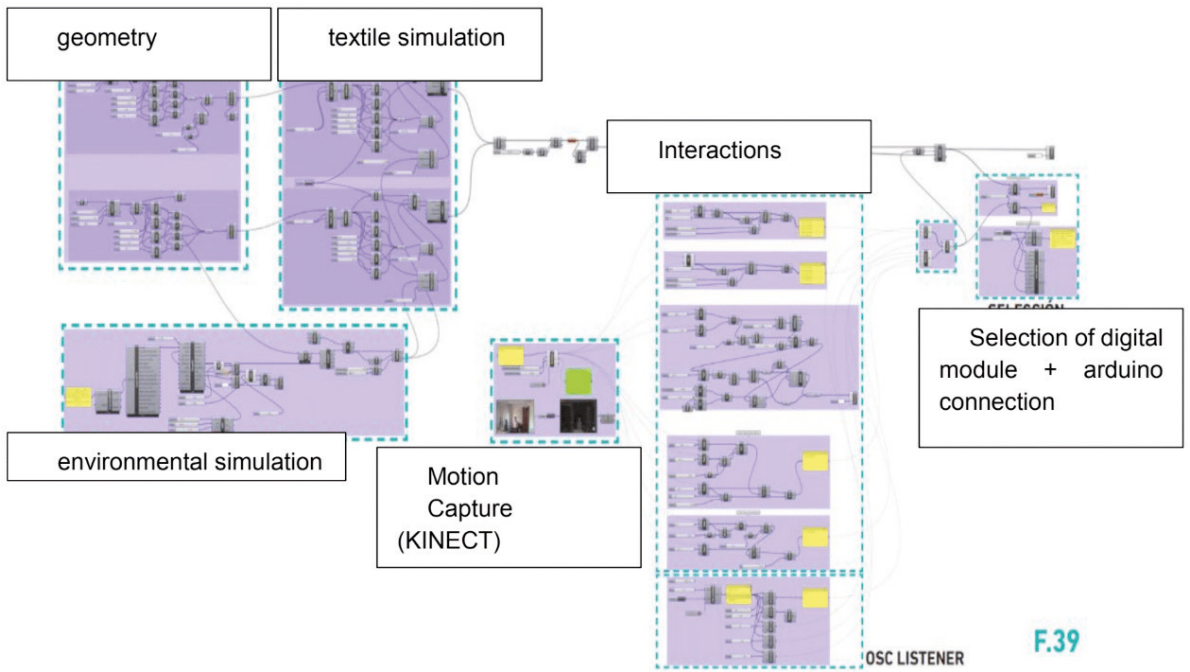

Figure 11. Responsive facade script. Own elaboration.

enormous potential in interactions, due to their soft capabilities and their compatibility with humans. This is why the application of soft robotics to interactions in architecture is a relevant research opportunity, especially if those interactions do not require a constant supply of energy to function. An example of this is the possibility of using nitinol with a low transition  $T^{\circ}$  ( $15^{\circ}$  or  $20^{\circ}$  C) to generate changes in a building with only body heat, without the need for electrical energy, software, or complex mechanisms, just the intelligence of the material.

One way to advance in the study of adaptive architecture is through hybridization. Hybridization allows existing elements that are apparently separated to be explored and brought together to obtain a

new result, different from the end for which they were made. In this particular case, it allowed the integration of two elements that apparently are not usually related, responsiveness and interaction. Although the system is a hybridization of several elements (grasshopper, arduino and kinect), they are open source. This gives the possibility that, in case of wanting to develop a complete facade, there is the possibility of adapting the programming to a language that is compatible with small board computers, such as Raspberry Pi. This would make it possible to stop using a conventional computer or laptops to control the facade, which would reduce the size of the system and the complexity and would make it even more accessible in economic terms.

## REFERENCES

- de Queiroz Nome, N., Carvalho, J. M., Verzola Vaz, C. E., & Nome, C. A. (2018). Pared cinética: Una fachada humana y ambientalmente responsiva. Un enfoque de educación en arquitectura. *Arquitecturas Del Sur*, 36(54), 58–69. <https://doi.org/10.22320/07196466.2018.36.054.05SAD>
- Dickey, R. (2017). Soft Systems: Rethinking Indeterminacy in Architecture as Opportunity Driven Research. *Protocols, Flows and Glitches*, Proceedings of the 22nd International Conference of the Association for Computer-Aided Architectural Design Research in Asia (CAADRIA), Bhatia 2012, 811–821.
- Majidi, Carmel. (2014). Soft Robotics: A Perspective—Current Trends and Prospects for the Future. *Soft Robotics*. 1. 5-11. [10.1089/soro.2013.0001](https://doi.org/10.1089/soro.2013.0001)
- Medina H., J., & Vélez N., P. (2015). “Soft Robotic”: Una nueva generación de robots. *Maskana*, 0(0), 109–118.
- Omar, A. faleh. (2017). Responsive Architecture a Place Making Design Strategy
- Whitesides, G. M. (2018). *Soft Robotics*. *Angewandte Chemie - International Edition*, 57(16), 4258–4273. <https://doi.org/10.1002/anie.201800907>